

- A** WHEN FORESLOPE IS 6:1 OR FLATTER
- B** FOR GUARDRAIL SECTIONS AND NON-GUARDRAIL SECTIONS WITH FORESLOPE STEEPER THAN 6:1
- C** SEE DETAILS "A" AND "B"
- D** 4' ROUNDING ON GUARDRAIL SECTIONS; NO ROUNDING REQUIRED WHEN FORESLOPE IS 6:1 OR FLATTER.
- E** GUARDRAIL DETAIL DOES NOT APPLY

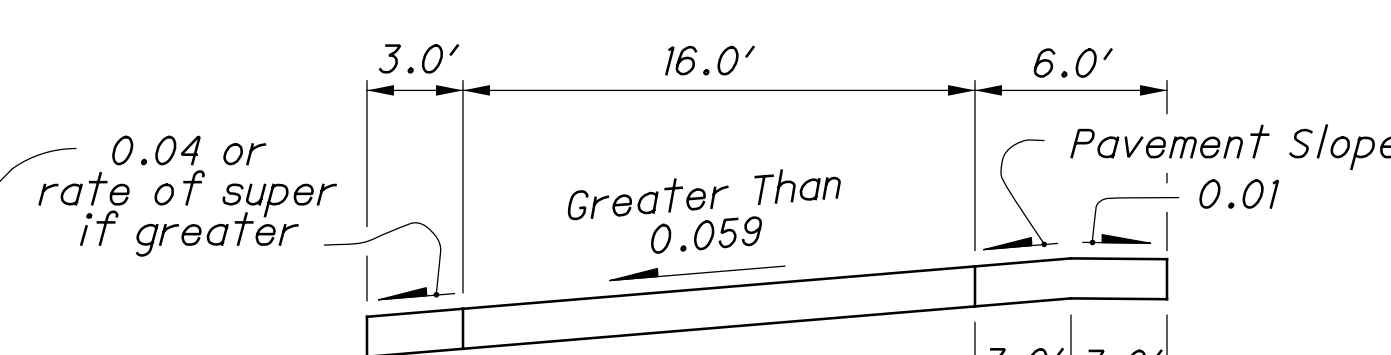
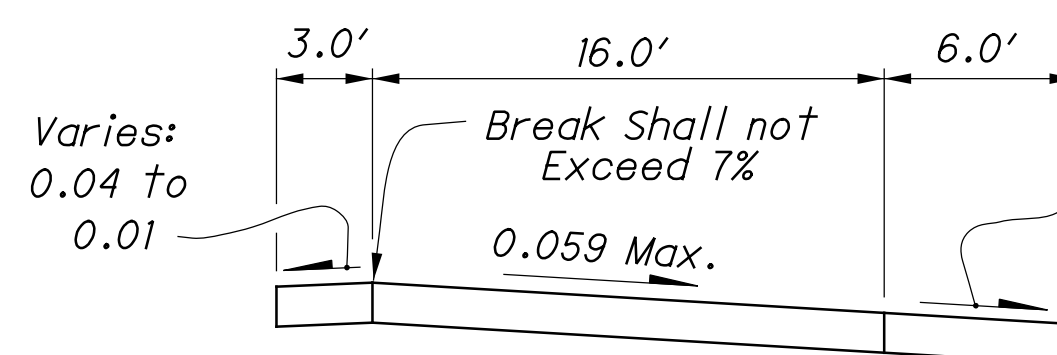
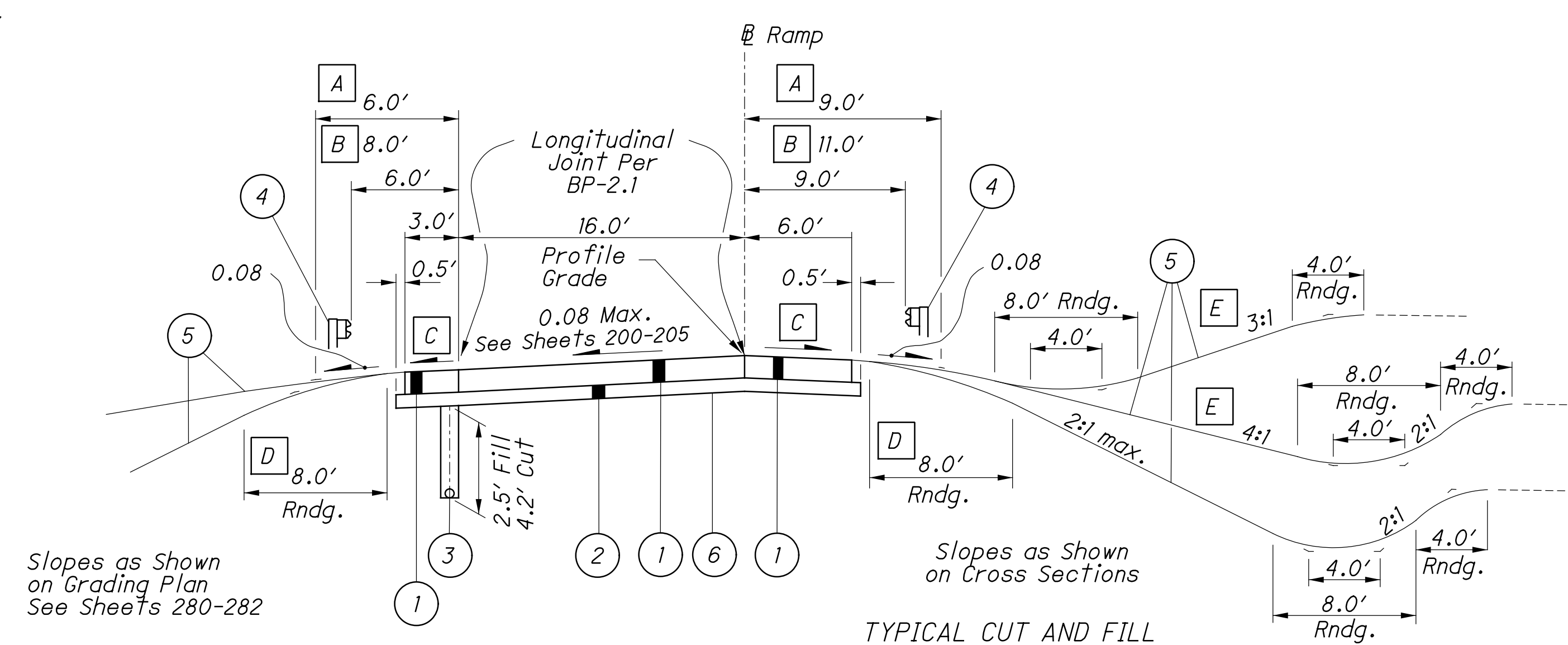
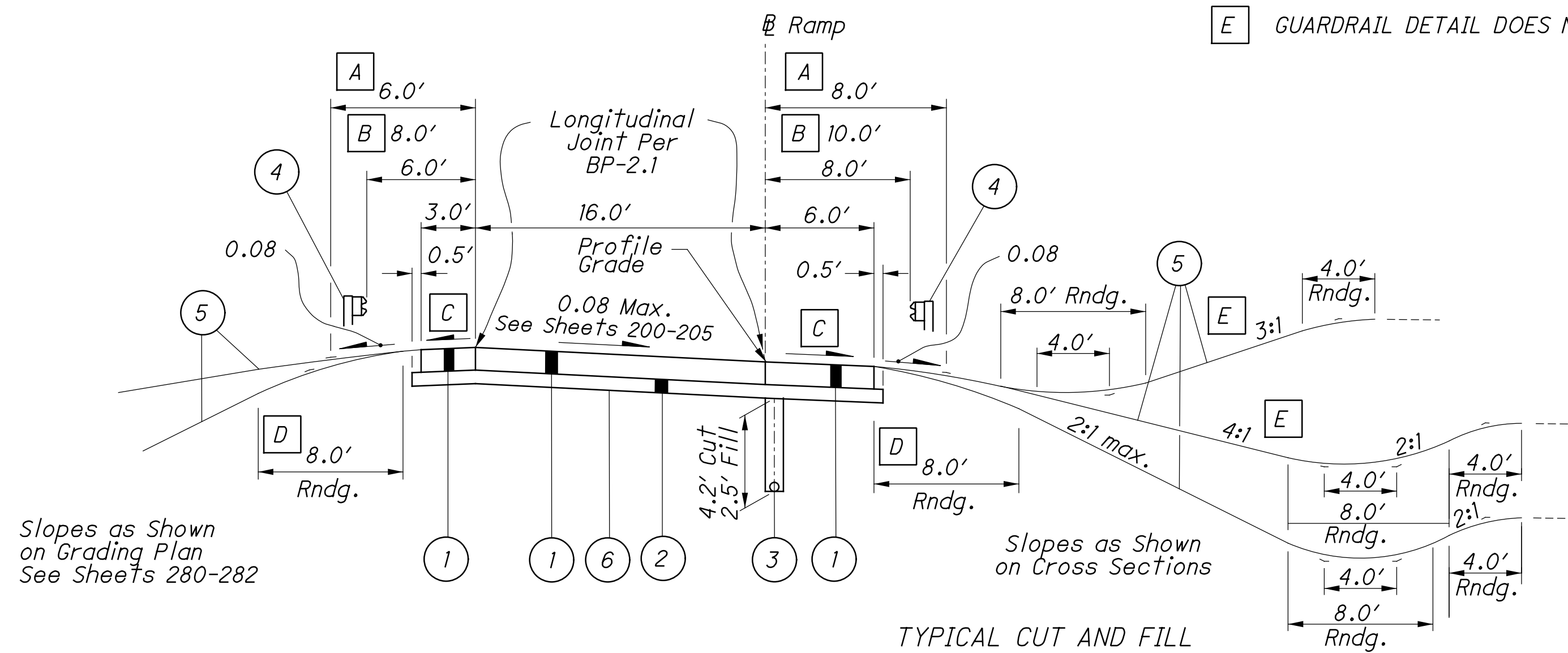

FOR LEGEND, SEE SHEET 9