

SECTION 1200 Plan Preparation

1201 General Plan Sheet Information	12-2
1201.1 Introduction	12-2
1201.2 Unit of Measure	12-2
1201.3 Plan Sheet Materials and File Format	12-2
1201.4 Plan Sheet Dimensions	12-2
1201.5 Title Block Information	12-2
1201.5.1 General	12-2
1201.5.2 Sheet Numbers	12-2
1201.5.3 Project Designation	12-3
1201.5.4 Sheet Title	12-3
1201.5.5 Quantity Validation	12-3
1201.5.6 Plan Scales	12-3
1201.5.7 North Arrow	12-3
1201.5.8 Additional Requirements	12-3
1201.5.9 PID Number	12-3
1202 Drafting	12-4
1202.1 Plan Scales	12-4
1202.2 Lettering	12-4
1202.3 Cross-Section Grids	12-4
1202.4 Drafting Conventions	12-5
1202.4.1 Text Orientation	12-5
1202.4.2 Placement of Leaders from Notes	12-6
1202.4.3 Placement of Leaders to, or from, a Circular Object	12-7
1202.4.4 Terminators	12-7
1202.4.5 Placement of Balloons	12-7
1202.4.6 Sheet Notes, Charts, and Summary Sheets	12-8
1202.4.7 Overdrafting	12-9
1202.4.8 Horizontal Curve Data	12-10
1202.4.9 Dashed Lines	12-11
1202.4.10 Direction of Cross-Hatch Lines	12-12
1202.4.11 Placement of Dimension Text	12-13
1202.4.12 Angular Dimensions	12-14
1202.4.13 Dimension in Crowded Conditions	12-15
1202.4.14 Dimensioning with a Dot	12-15
1202.4.15 Dimensioning at Angles	12-16
1202.4.16 Dimensioning an Object	12-17
1202.4.17 Crossing Dimension Lines	12-18
1202.4.18 Grouped Dimensions	12-19
1202.4.19 Use of "Typical"	12-20
1202.5 Computer-Aided Drafting and Design (CADD)	12-21
1203 Standard Drawings	12-21
1203.1 Standard Construction Drawings	12-21
1203.2 Plan Insert Sheets	12-21
Figures	12-22

SECTION 1200 Plan Preparation

1201 General Plan Sheet Information

1201.1 Introduction

The purpose of a set of construction plans is to delineate the proposed work with sufficient design details, supplemented with notes, calculations and summaries of quantities, in such a manner that it can be clearly and uniformly interpreted by engineers and contractors. Sufficient data must be provided to enable the contractor to make an intelligent bid and perform the work as intended. Clarity, completeness and conciseness are essential to avoid misinterpretation. Unnecessary details should be avoided.

1201.2 Unit of Measure

Plans shall be prepared using the English system of units.

1201.3 Plan Sheet Materials and File Format

With the exception of some local-let projects, plans shall be submitted in a PDF electronic image format. Text-based documents should be provided in searchable PDF files.

Some external agencies do not allow submission of electronic images as final documents. In instances where hard copy (i.e., paper) documents are required, the District Planning and Engineering Administrator will determine whether the hard copy document will be created by the District or by the consultant. The requirement to produce hard copy documents shall be included in the Scope of Services document.

Unacceptable hard copy originals include: mylars, negatives, sepias, vellums, damaged sheets, dark backgrounds, pencil drawings, zipatone, paste-ons, stick-ons or bond papers. Decals are not permitted.

1201.4 Plan Sheet Dimensions

All plan sheets, including plans prepared by sub-consultants (e.g., soil profile sheets), shall be the same size and format. Electronic image files shall be formatted to be 22 inches by 34 inches and shall be capable of being bound and punched when printed as shown in **Figure 1201-1**.

Simplified plans shall be formatted to quarter size (11 inches by 17 inches).

1201.5 Title Block Information

1201.5.1 General

Figure 1201-1 shows the location of the border and title block for standard size (22 inches by 34 inches) plan sheets. An example title block is shown in **Figure 1201-2**. The **Bridge Design Manual** and **Real Estate Policies and Procedures Manual** show standard structures and right-of-way title sheet blocks, respectively. All plan sheets shall display, as a minimum, the plan sheet number, the project designation and the sheet title. Additional items that may be required include quantity validation initials, plan scales and a north arrow.

1201.5.2 Sheet Numbers

Sheet numbers are shown in the split circle in the lower right corner of the sheet. The number at the top of the circle is the actual sheet number, in consecutive order, and the bottom number is the total number of sheets in the plan based on the last actual sheet number. Sheets that require supplemental sheet numbers (e.g., structure plans and right-of-way plans) may be grouped within the plan.

Occasionally, sheets may need to be inserted into a set of plans that has already been numbered.

SECTION 1200 Plan Preparation

These sheets should be labeled with the number of the preceding sheet, followed by consecutive letters (e.g., 26A, 26B...26Z) and then by consecutive double letters (e.g., 26AA, 26BB...26ZZ). This will permit the insertion of up to 52 additional sheets. The bottom number in the split circle will still be the number of the last sheet. The last sheet shall not be labeled with a number/letter combination. If a significant number of sheets need to be inserted or added to a set of plans, consideration should be given to renumbering the entire set.

1201.5.3 Project Designation

The project designation is normally the county code, route number, and section number as shown in the plan title on the Title Sheet (**Section 1302**). When multiple section numbers are involved and space in the title block does not permit a complete listing, the county, all route numbers, and the first section number followed by the words “and various” should be shown.

1201.5.4 Sheet Title

The sheet title should include: the general plan sheet description (e.g., Schematic Plan, General Summary, Plan and Profile, Cross-Sections, etc.), the applicable roadway, if not obvious (e.g., U.S. 35, S.R. 315, Ramp A, Main Street, Connecting Road, etc.) and the applicable station limits.

1201.5.5 Quantity Validation

Where sheets include quantities, space should be provided for the date and initials of the individuals who calculated and checked the quantities.

1201.5.6 Plan Scales

A bar scale should be shown whenever a plan view is required. Bar scales are not normally required in the vertical dimension on profiles or for cross-sections, since these should be adequately labeled. If the plan sheet requires more than one scale, bar scales should be shown on the plan and the words “See Details” shown in the title block.

1201.5.7 North Arrow

A north arrow should be shown as accurately as possible (usually $\pm 5^\circ$) whenever a plan view is required. If the plan sheet contains more than one plan view, no north arrow should be shown in the title block.

1201.5.8 Additional Requirements

The **Bridge Design Manual**, Section 100 and the **Real Estate Policies and Procedures Manual**, Section 3100 contain additional requirements for bridge and right-of-way plan sheets, respectively.

1201.5.9 PID Number

Each project is assigned a unique Project Identification (PID) Number when it is entered into Ellis. This number should be shown in the proper space on the title block. On occasion, this number may change during project development. The plan, file names and directory structure should always reflect the latest number, with former numbers noted on the Title Sheet. See Section 1302 for additional information regarding the title sheet.

SECTION 1200 Plan Preparation

1202 Drafting

1202.1 Plan Scales

The designer should prepare plans keeping in mind that a 22-inch by 34-inch full-size plan sheet may be reproduced to a 11 inch by 17-inch print.

It is recommended that plan sheet scales normally be limited to the following:

For English unit plan sheets: 1:1, 1:5, 1:10, 1:20, 1:50, 1:100, 1:200, 1:500 or 1:1000. These scales are in inches per foot. For example, 1:20 indicates 1 inch on the plan sheet equals 20 feet in the field.

Scales that are multiples of ten of the above scales may be used (e.g., 1:2000 is a multiple of 1:200). If it is believed that a better product will result, other scales may be used. The intent should always be to clearly and adequately show the work to be performed, keeping in mind that the plans used during construction could be reduced to one-half the original scale (e.g., 1:20 full size prints become 1:40 quarter size prints).

1202.2 Lettering

Fancy lettering should not be used. Lettering should be oriented in such a manner that it can be read from either the bottom or right side of the plan sheet. The minimum text size is 0.14 inches.

1202.3 Cross-Section Grids

Acceptable grid systems for cross-sections and profiles are shown in **Figure 1202-1**. Letters and lines should be bolder when they are superimposed over cross-section grids.

SECTION 1200 Plan Preparation

1202.4 Drafting Conventions

The following sections present the preferred standard drafting guidelines for roadway construction plans. Standard drafting symbols are available from the Office of CADD and Mapping Services, [CADD Services](#) website.

1202.4.1 Text Orientation

Text on inclined lines should be orientated as shown.

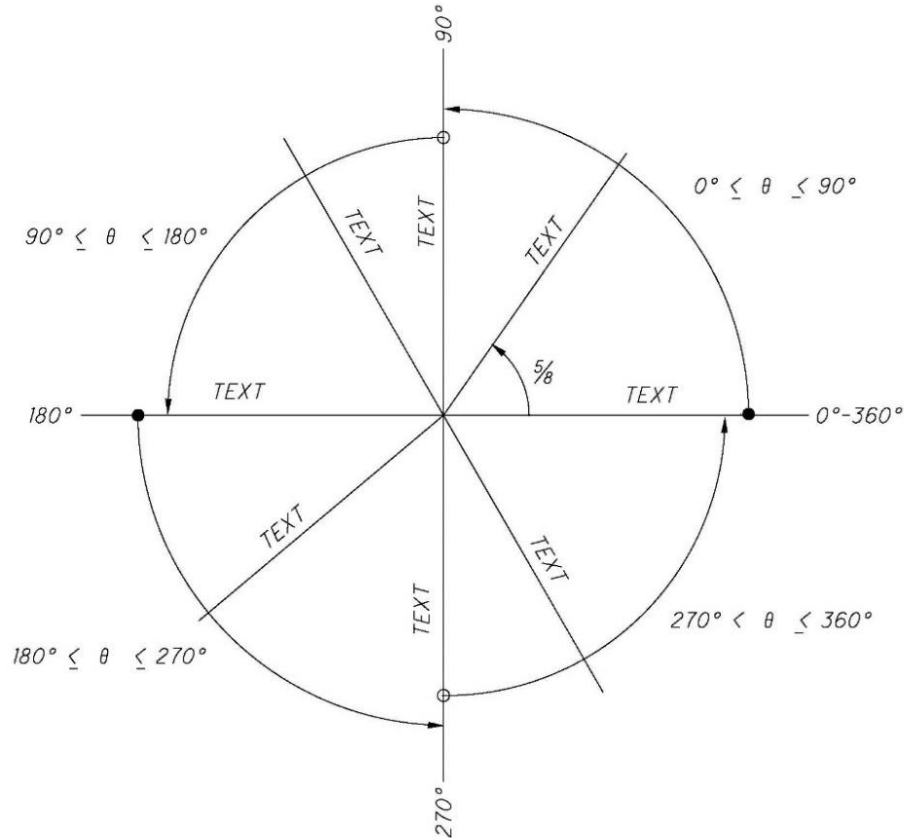

SECTION 1200 Plan Preparation

1202.4.2 Placement of Leaders from Notes

A leader line should originate from the first line on the left, the last line on the right, or from a vertical bar on either side, as shown. The leader should generally be an inclined straight line, if possible, except for the short horizontal shoulder extending from mid-height of the lettering at the beginning or end of a note.

Where space prohibits the use of straight leader lines, curved leaders may be used. Curves should be smooth and simple, beginning with a short, horizontal, shoulder extending from mid-height of the lettering.

CORRECT

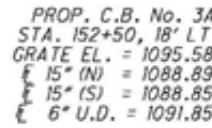
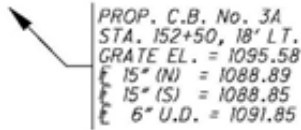
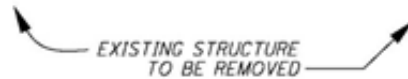
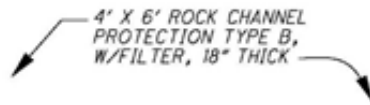

INCORRECT



SECTION 1200 Plan Preparation

1202.4.3 Placement of Leaders to, or from, a Circular Object

A leader to, or from, a circular object should extend radially, so that if extended it would pass through the center of the circle.

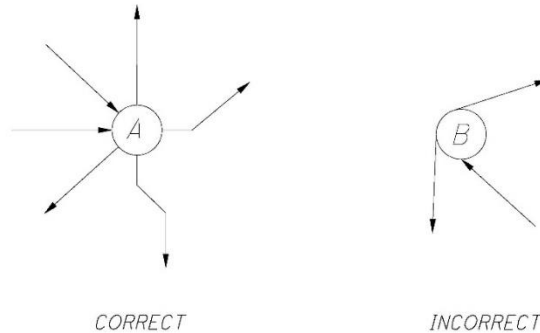

1202.4.4 Terminators

Leaders should terminate with an arrowhead when pointing to an object or to an edge and should terminate as shown when pointing to a surface or layer.

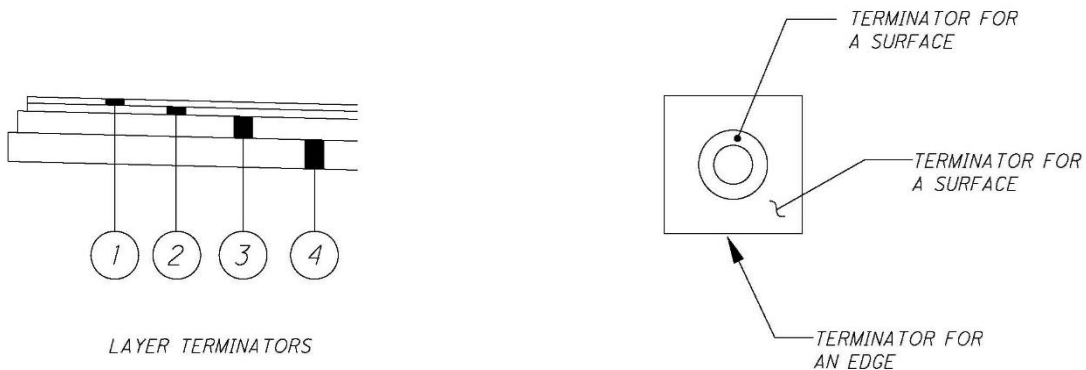

1202.4.5 Placement of Balloons

Balloons on typical sections should be aligned as much as possible, rather than placed randomly around the section. The leader lines extending from the bubbles to pavement layers should be vertical, where possible. Other items, such as guardrail and underdrains may be labeled with straight, inclined, leaders. All leaders should end with a terminator.

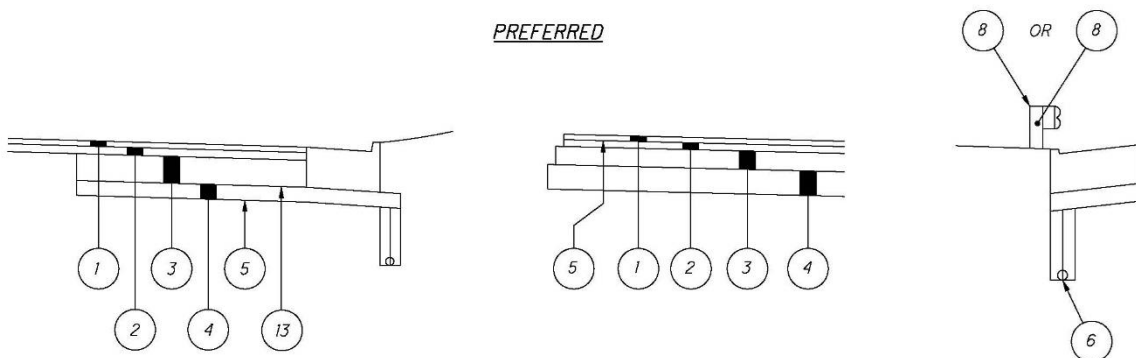

SECTION 1200 Plan Preparation

TRY TO AVOID THESE CONFIGURATIONS

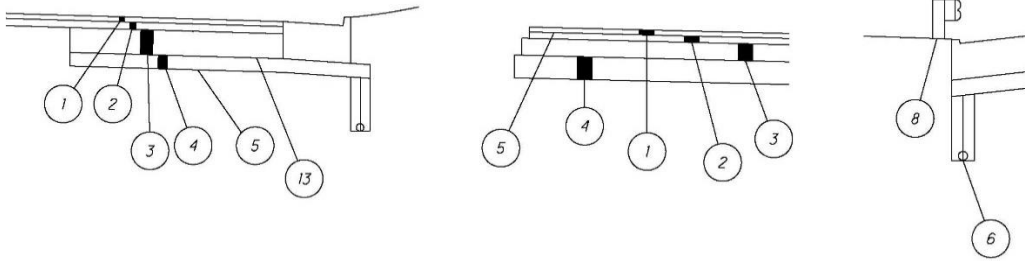

1202.4.6 Sheet Notes, Charts, and Summary Sheets

Groups of sheet notes shall be left justified. Right justification is optional.

Text in charts should be placed slightly above the lines (never directly on the line) to improve readability. It is recommended to leave an empty line at the beginning and end of the chart and between every fifth item to accommodate future additions.

ITEM	ITEM EXT.	GRAND TOTAL	UNIT	DESCRIPTION
<i>ROADWAY</i>				
201	11000	LS		CLEARING AND GRUBBING
202	23000	32738	SY	PAVEMENT REMOVED
202	23500	1503	SY	WEARING COURSE REMOVED
202	32000	1953	FT	CURB REMOVED
202	32001	927	FT	CURB REMOVED, AS PER PLAN
202	38000	12687.5	FT	GUARDRAIL REMOVED
202	38700	34	EACH	GUARDRAIL POST REMOVED
202	58500	3	EACH	CATCH BASIN ABANDONED
203	10000	39679	CY	EXCAVATION
203	20000	12954	CY	EMBANKMENT
204	10000	71464	SY	SUBGRADE COMPACTION
606	15050	11650	FT	GUARDRAIL, TYPE MGS
606	15150	175	FT	GUARDRAIL, TYPE MGS HALF POST SPACING
606	25550	12	EACH	ANCHOR ASSEMBLY, MGS TYPE A
606	26150	12	EACH	ANCHOR ASSEMBLY, MGS TYPE E
606	26550	23	EACH	ANCHOR ASSEMBLY, MGS TYPE T

Numbers with decimals in a chart should be aligned in columns along the decimal point. Integer values should be either right justified or centered in columns.

606.93		-0.19	-0.0156		33+92.16	
607.13		-0.16	-0.0133		34+00.00	
607.76		-0.05	-0.04		+25.00	
608.04		0.00	0.0		+37.09	
608.34		+0.05	+0.0042		+50.00	
608.88		+0.16	+0.013		+75.00	
609.02		+0.19	+0.0156		+82.02	
609.38		+0.27	+0.02		35+00.00	
609.84		+0.37	+0.33		+25.00	
610.26		+0.48	+0.4		+50.00	
610.63		+0.58	+0.48		+75.00	
610.97		+0.69	+0.575		36+00.00	

SECTION 1200 Plan Preparation

1202.4.7 Overdrafting

It is preferable to place dimensions outside areas which contain cross-hatching and other line work. Where this is not possible, the cross-hatching, or line work, should be broken around the text. Hatch lines should never cross through text, however, certain critical line work elements, such as centerlines may pass through text.

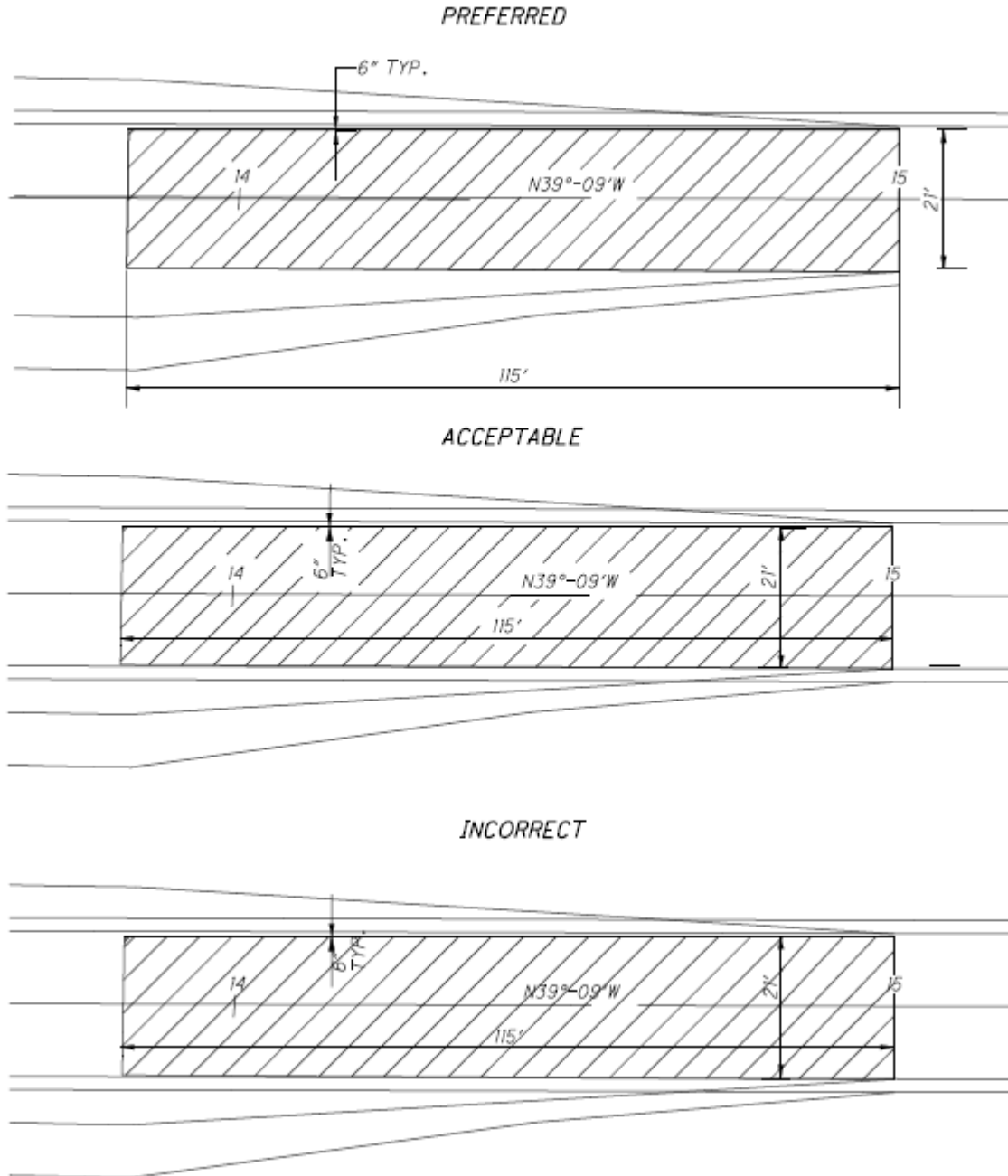

SECTION 1200 Plan Preparation

1202.4.8 Horizontal Curve Data

The curve data should be shown on the inside of the specified curve and between the PC and PT, where possible. As shown, it is permissible to jog the lines for the PC and PT, provided the initial portions of the lines extending from the curve are along the correct radius.

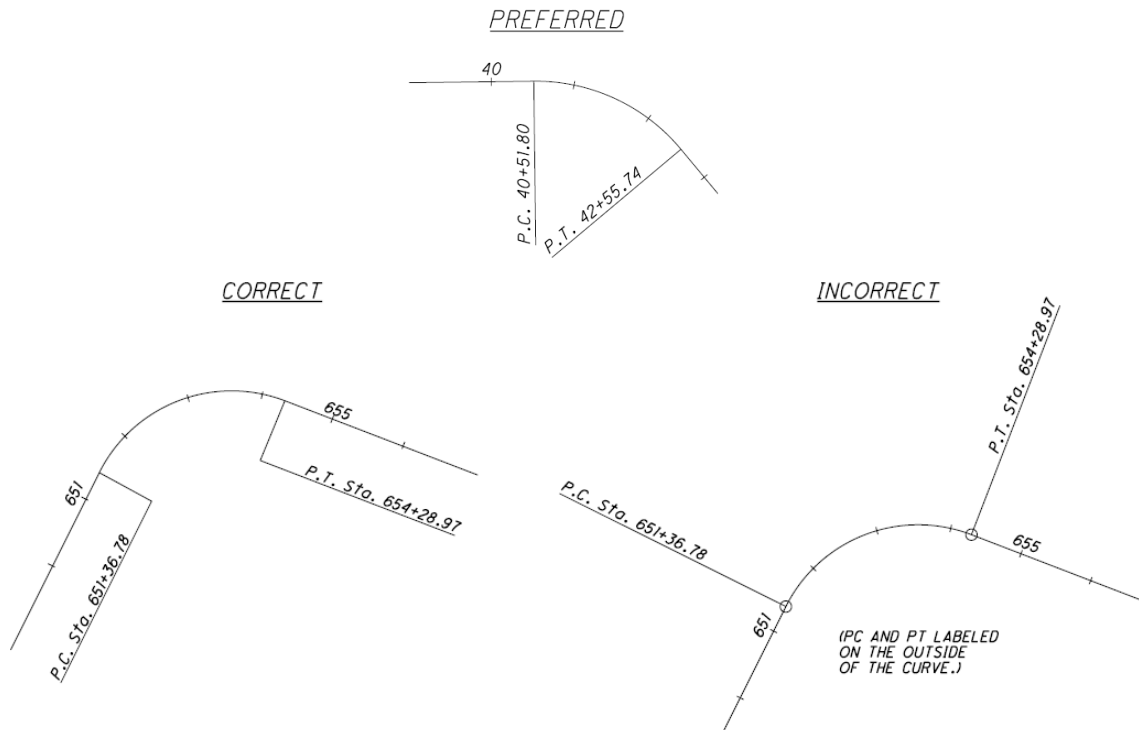

When space prohibits or when an alignment has a large number of horizontal curves, label each curve and tabulate the curve data. If it is necessary to tabulate curve data for a few curves along an alignment, then all curves should be tabulated to provide consistency.

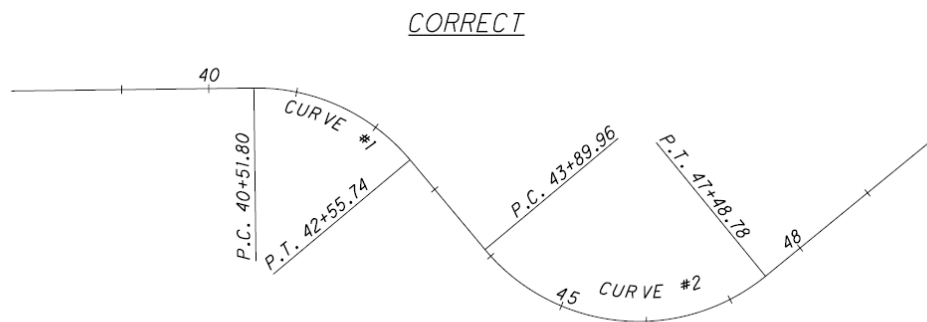

CURVE #1 DATA	CURVE #2 DATA
P.I. STA. 41+61.02, @ CONST. TRUMP RD.	P.I. STA. 46+17.51, @ CONST. TRUMP RD.
$\Delta = 50^\circ 48' 16''$ RT.	$\Delta = 89^\circ 23' 07''$ LT.
$D_c = 24^\circ 54' 40''$	$D_c = 24^\circ 54' 40''$
$R = 230.00'$	$R = 230.00'$
$T = 109.22'$	$T = 227.55'$
$L = 203.94'$	$L = 358.82'$
$E = 24.62'$	$E = 93.54'$
$e_{max} = 0.025$	$e_{max} = 0.025$

SECTION 1200 Plan Preparation

1202.4.9 Dashed Lines

When needed for clarity, dashed lines should connect at all points of intersection and points of tangency. (You may need to subdivide certain CADD cells into individual elements in order to connect the lines properly.)

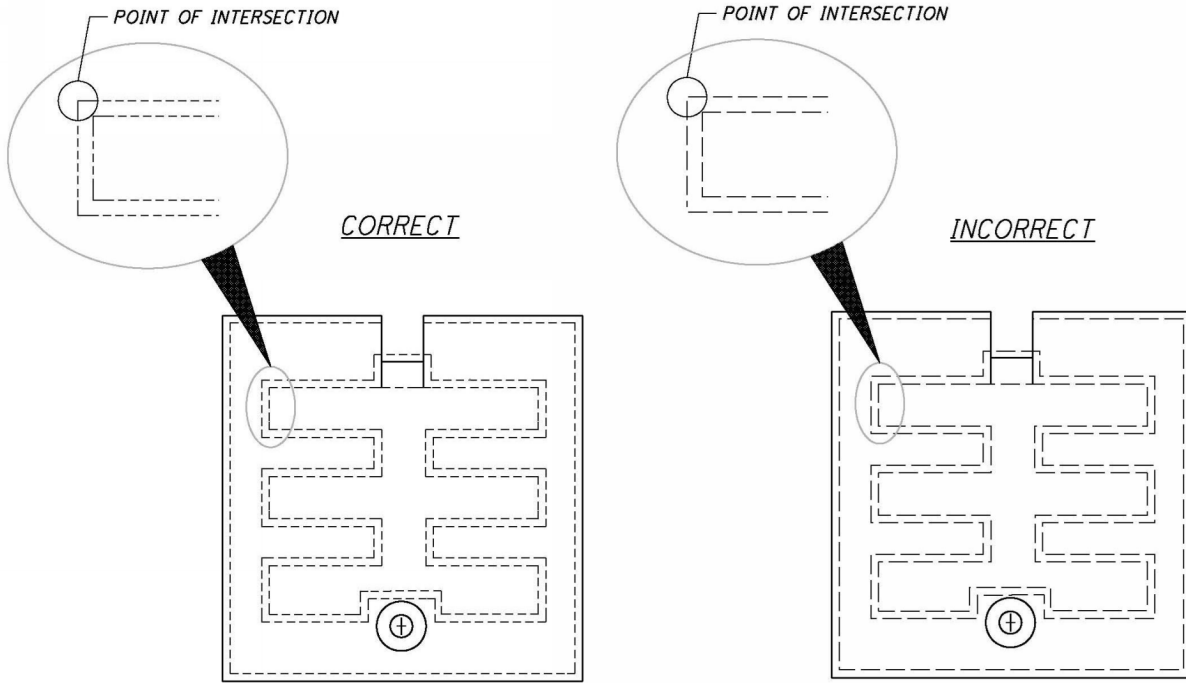

When needed for clarity, a gap should be shown at all locations where a visible edge becomes hidden by another surface as shown below.

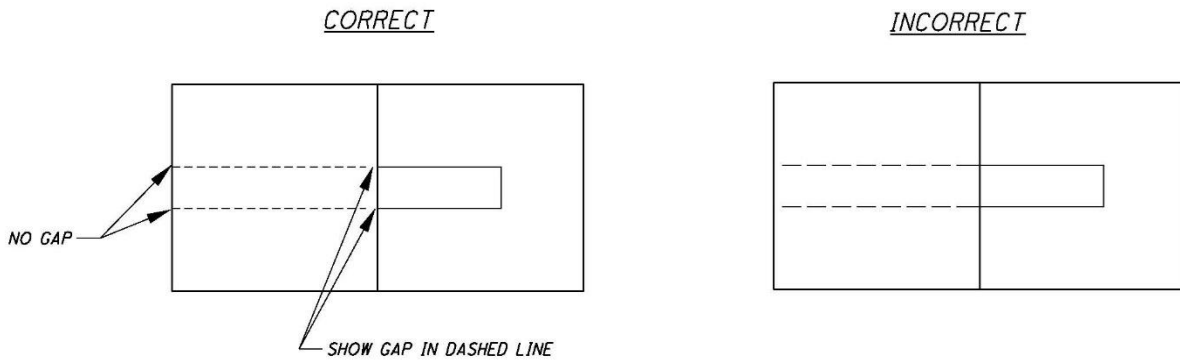

SECTION 1200 Plan Preparation

1202.4.10 Direction of Cross-Hatch Lines

In general, draw cross-hatched lines at 45° with horizontal. If cross-hatch lines drawn at 45° with horizontal would be parallel or perpendicular (or nearly so) to a prominent visible outline, the angle should be modified.

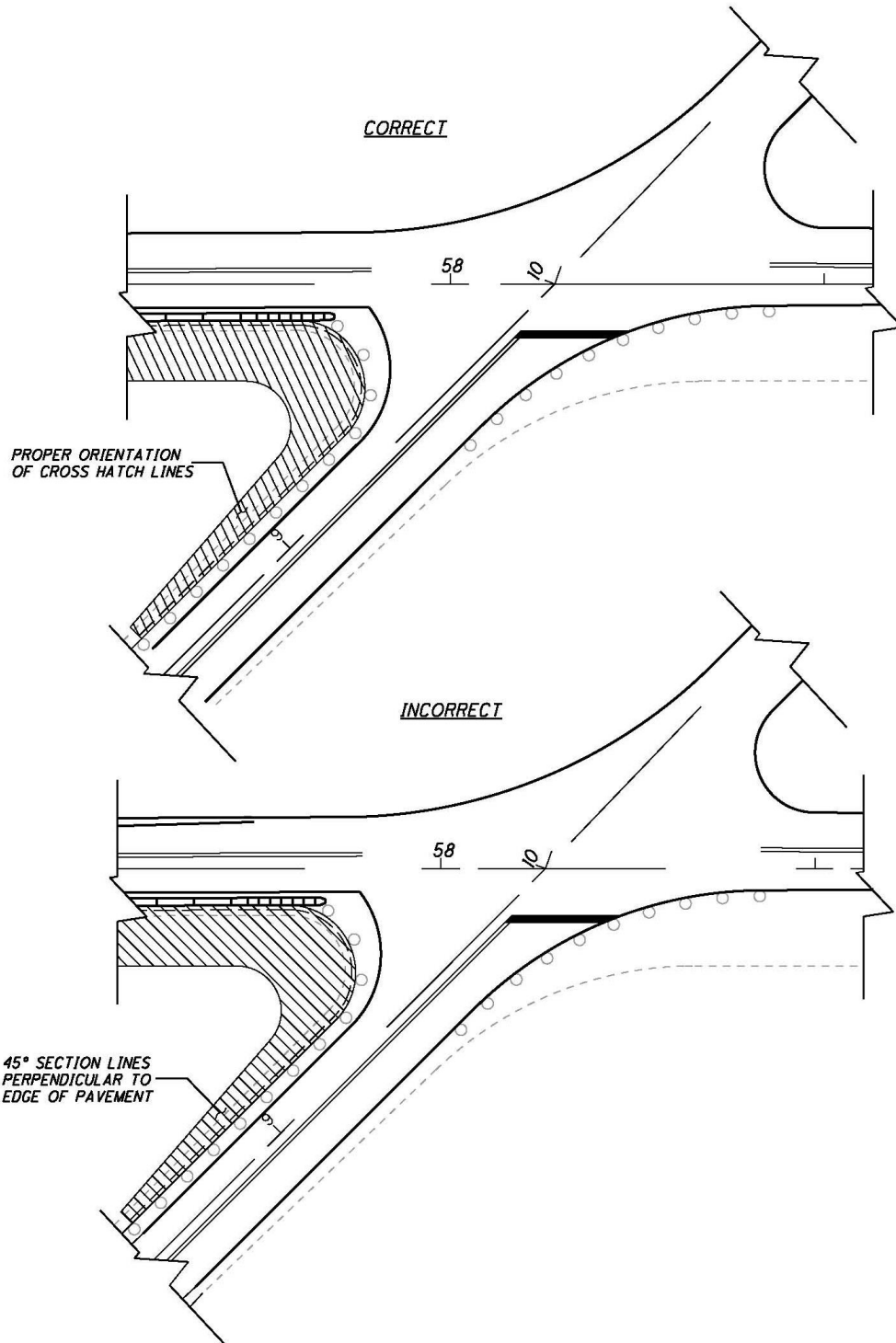

SECTION 1200 Plan Preparation

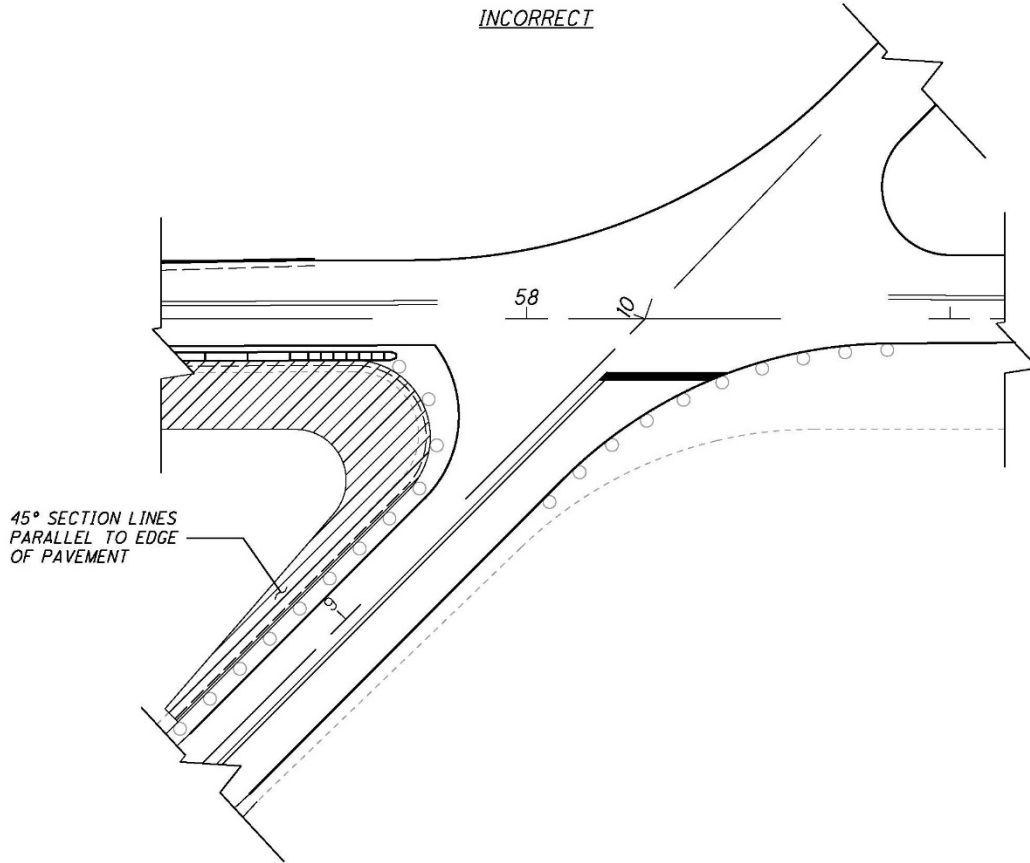

1202.4.11 Placement of Dimension Text

Generally, text should be placed above a solid dimension line and oriented parallel to the line, as shown below. Horizontal text shall be read parallel to the bottom edge of the sheet. Vertical text shall be read parallel to the right edge of the sheet. Text in dimension strings should be placed at the same level.

See examples below:

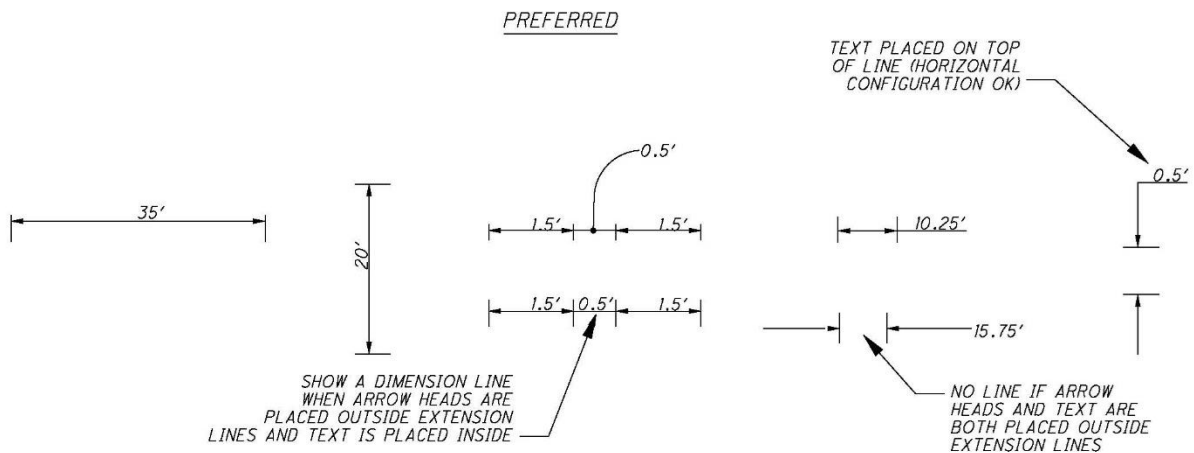

SECTION 1200 Plan Preparation

TRY TO AVOID THESE CONFIGURATIONS

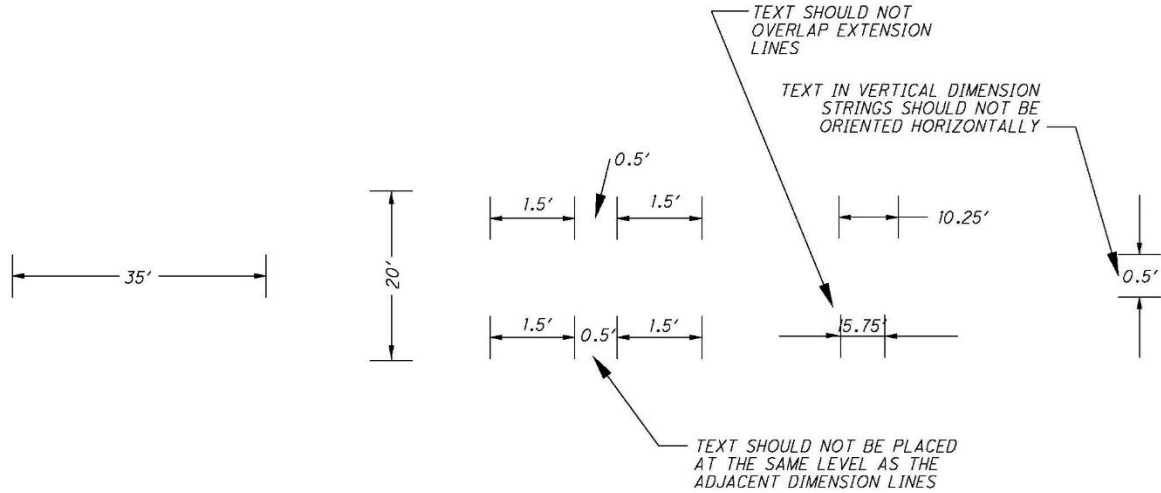

1202.4.12 Angular Dimensions

Angular dimensions should be placed with an arc drawn from the vertex of the angle.

CORRECT

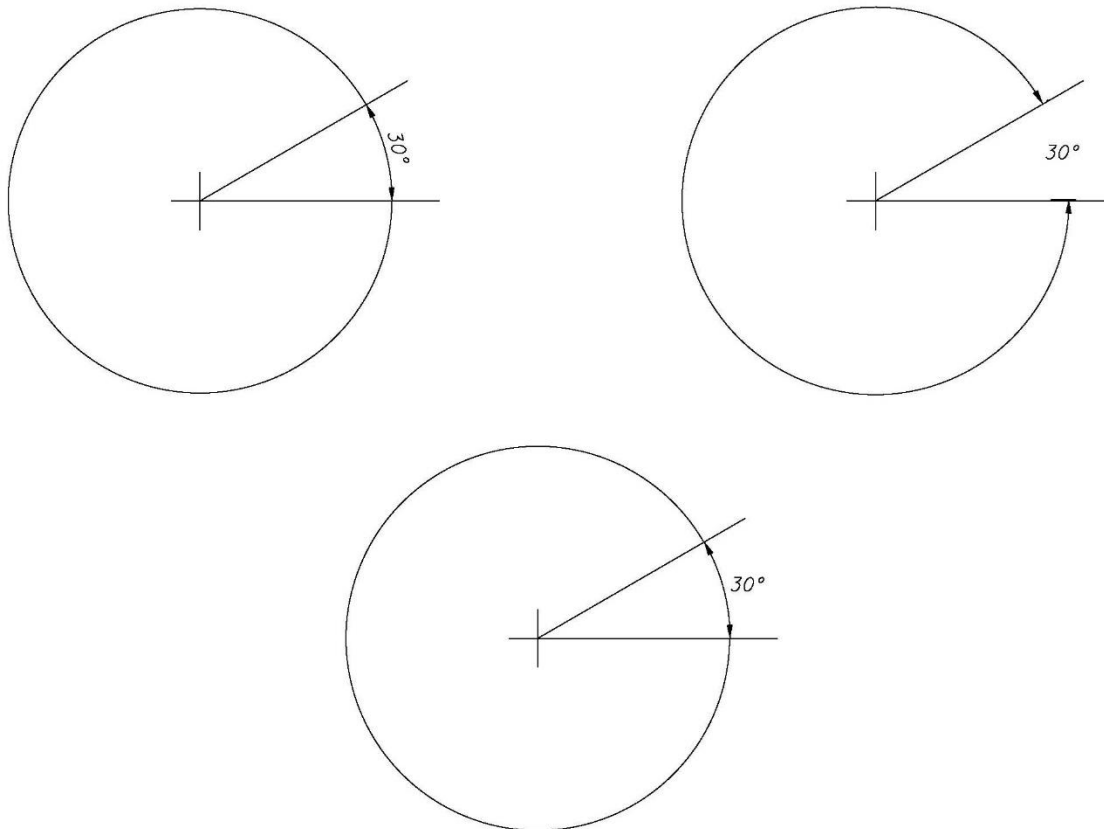

SECTION 1200 Plan Preparation

INCORRECT

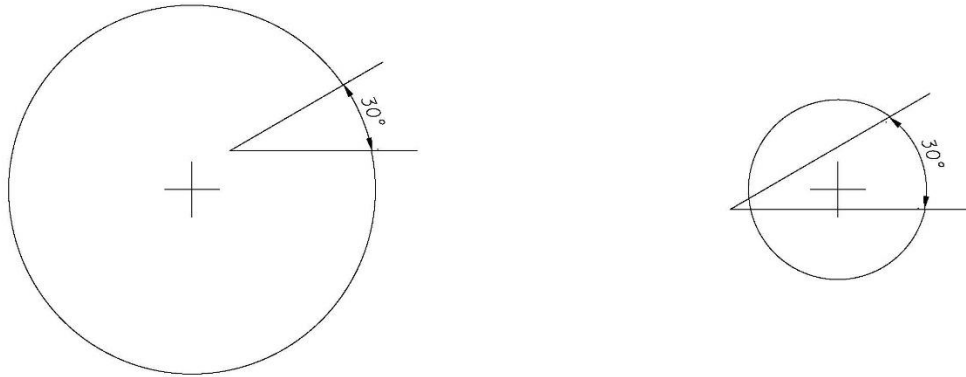

1202.4.13 Dimension in Crowded Conditions

In crowded conditions, gaps in extension lines near arrowheads may be left as shown below, in order to clarify the dimensions.

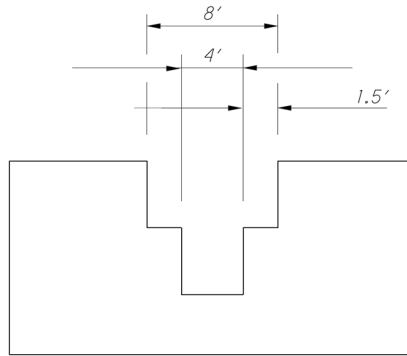

1202.4.14 Dimensioning with a Dot

If the dimension cannot be placed on the dimension line, then a dot with a curved leader may be used as shown.

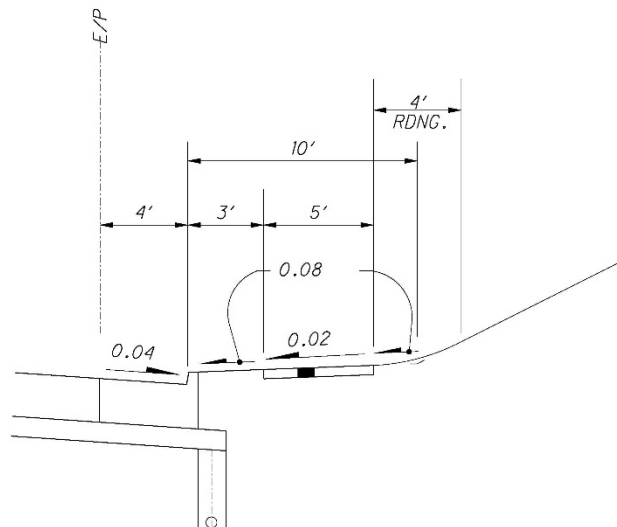

SECTION 1200 Plan Preparation

1202.4.15 Dimensioning at Angles

Dimension lines must always be drawn parallel to the edge being dimensioned. Extension lines are usually drawn at right angles to the edge being dimensioned: However, an exception may be made in the interest of clarity, as shown.

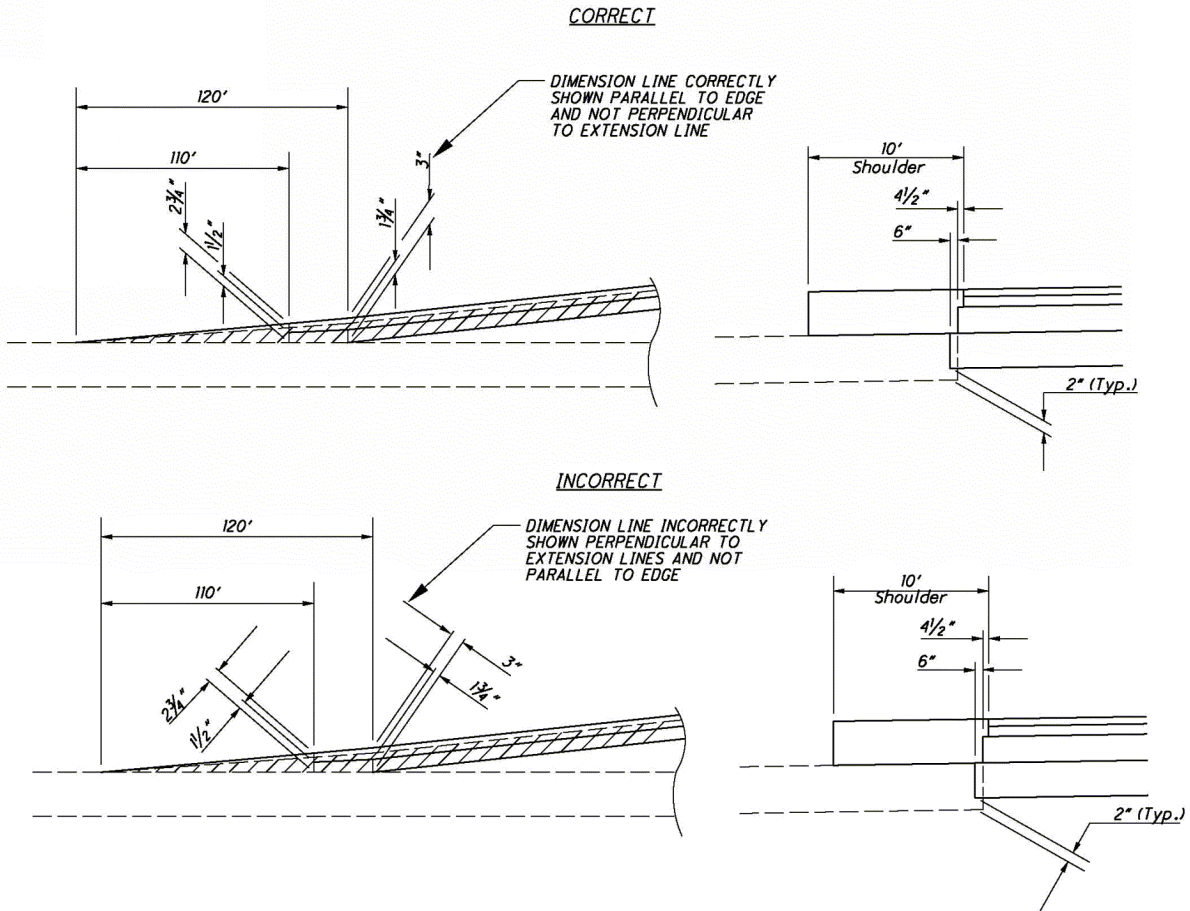

SECTION 1200 Plan Preparation

1202.4.16 Dimensioning an Object

Place shorter dimensions nearest to the object outline. As shown below, crossing the extension lines is acceptable. Dimension lines should not cross extension lines as a result of placing the shorter dimensions on the outside.

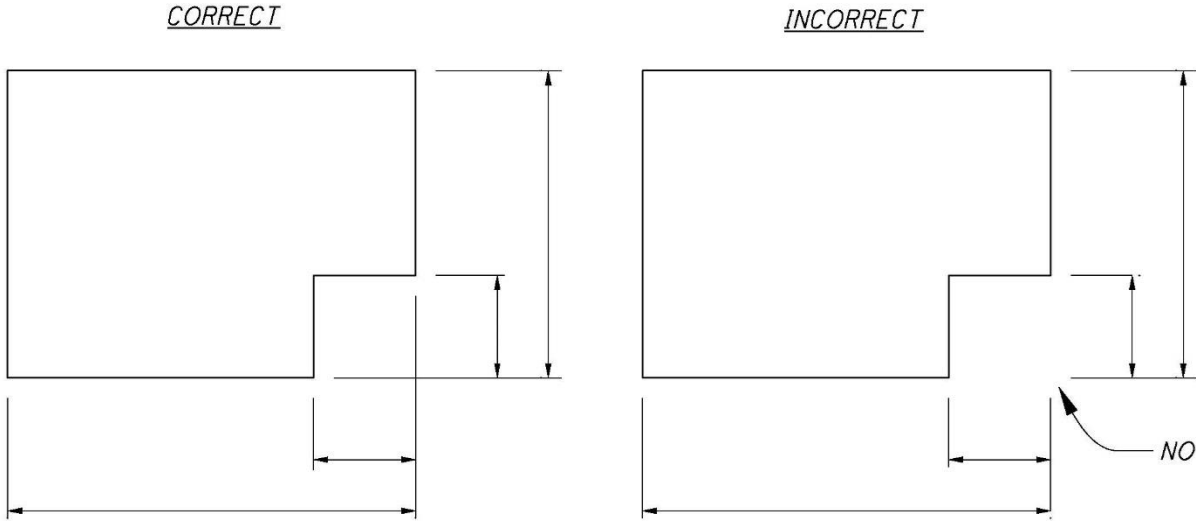

Extension lines should not be shortened. Also, a dimension line should never coincide with or form a continuation of any line of the drawing. If possible, dimensions should always be placed off the object.

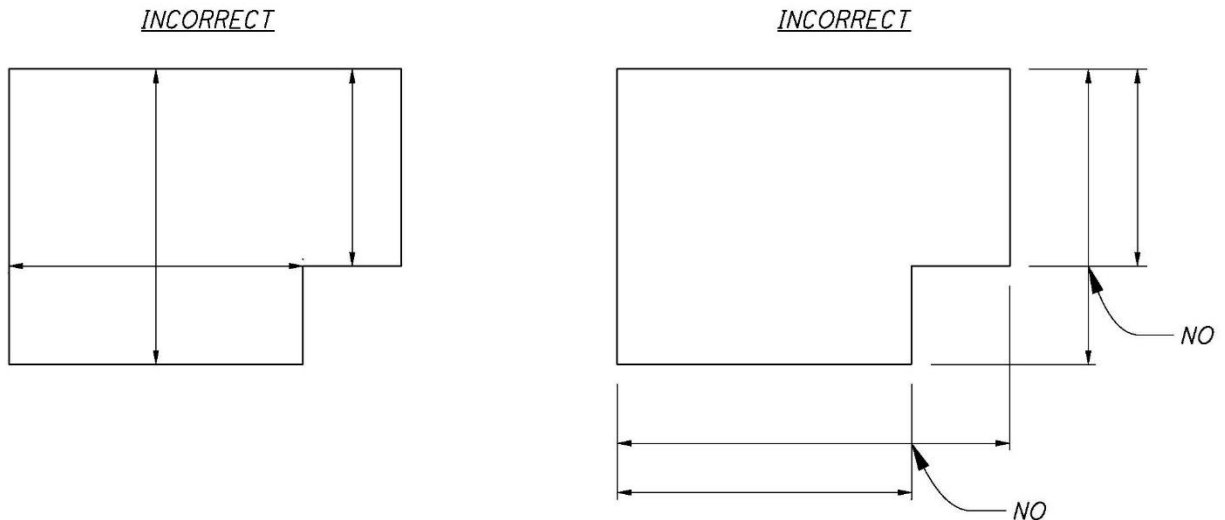

SECTION 1200 Plan Preparation

1202.4.17 Crossing Dimension Lines

Extension lines should not be broken. In addition, lines should not be centered at object edges.

CORRECT

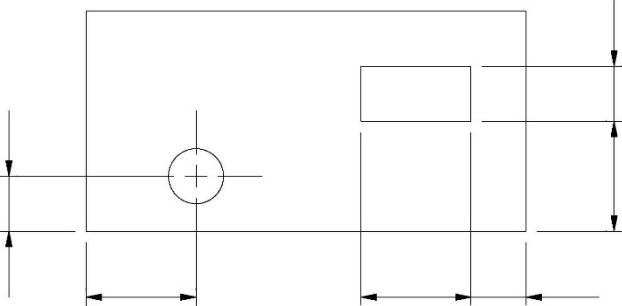

INCORRECT

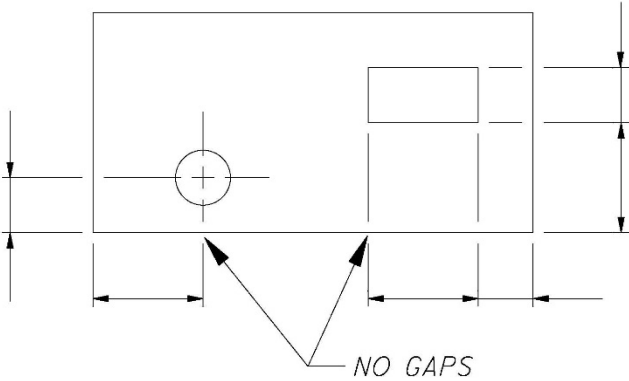

SECTION 1200 Plan Preparation

1202.4.18 Grouped Dimensions

Grouped dimensions should be in line, evenly spaced and off the object being dimensioned.

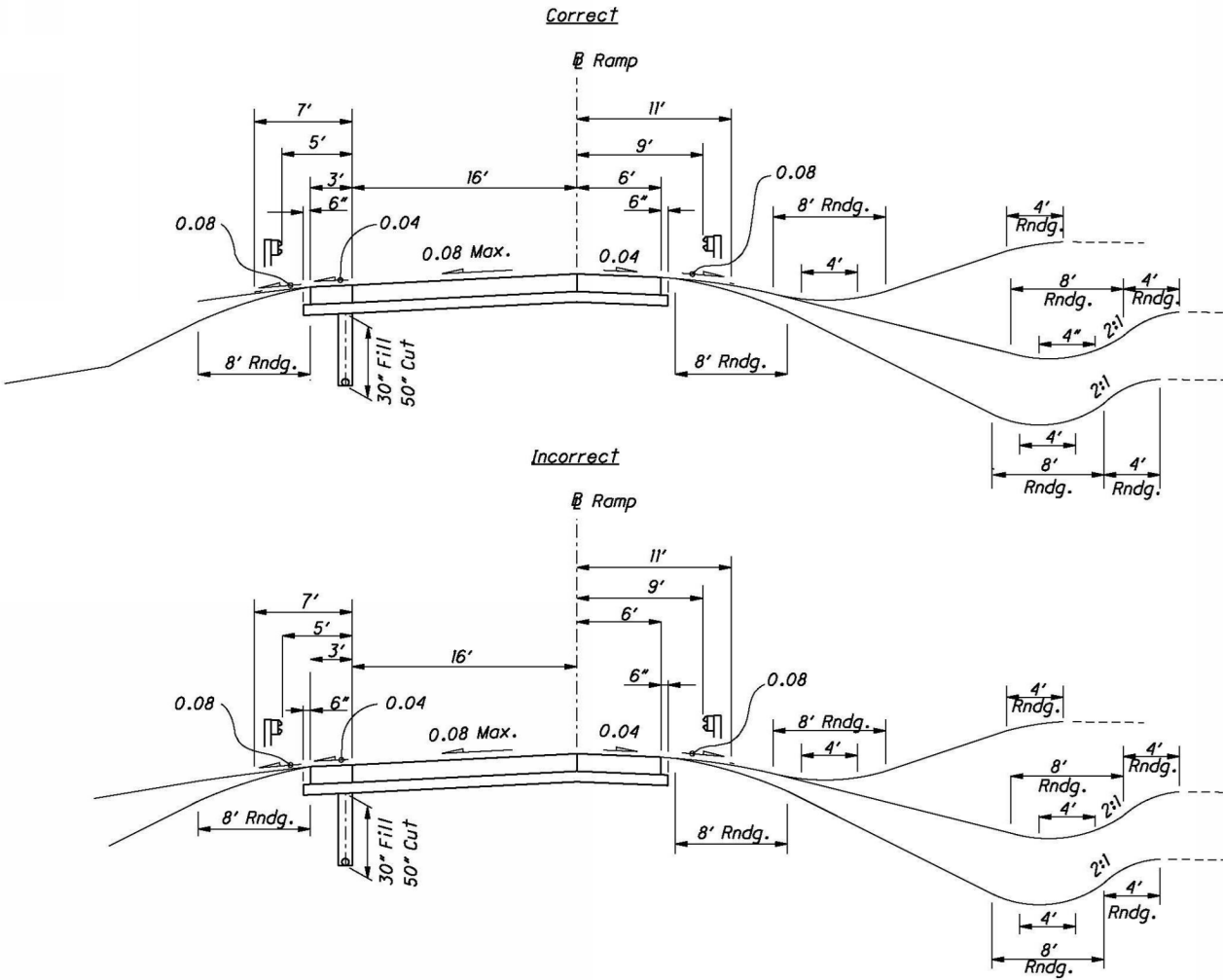

SECTION 1200 Plan Preparation

1202.4.19 Use of "Typical"

For symmetrical objects and repetitive dimensions, use the word "typical" to simplify dimensioning, as shown:

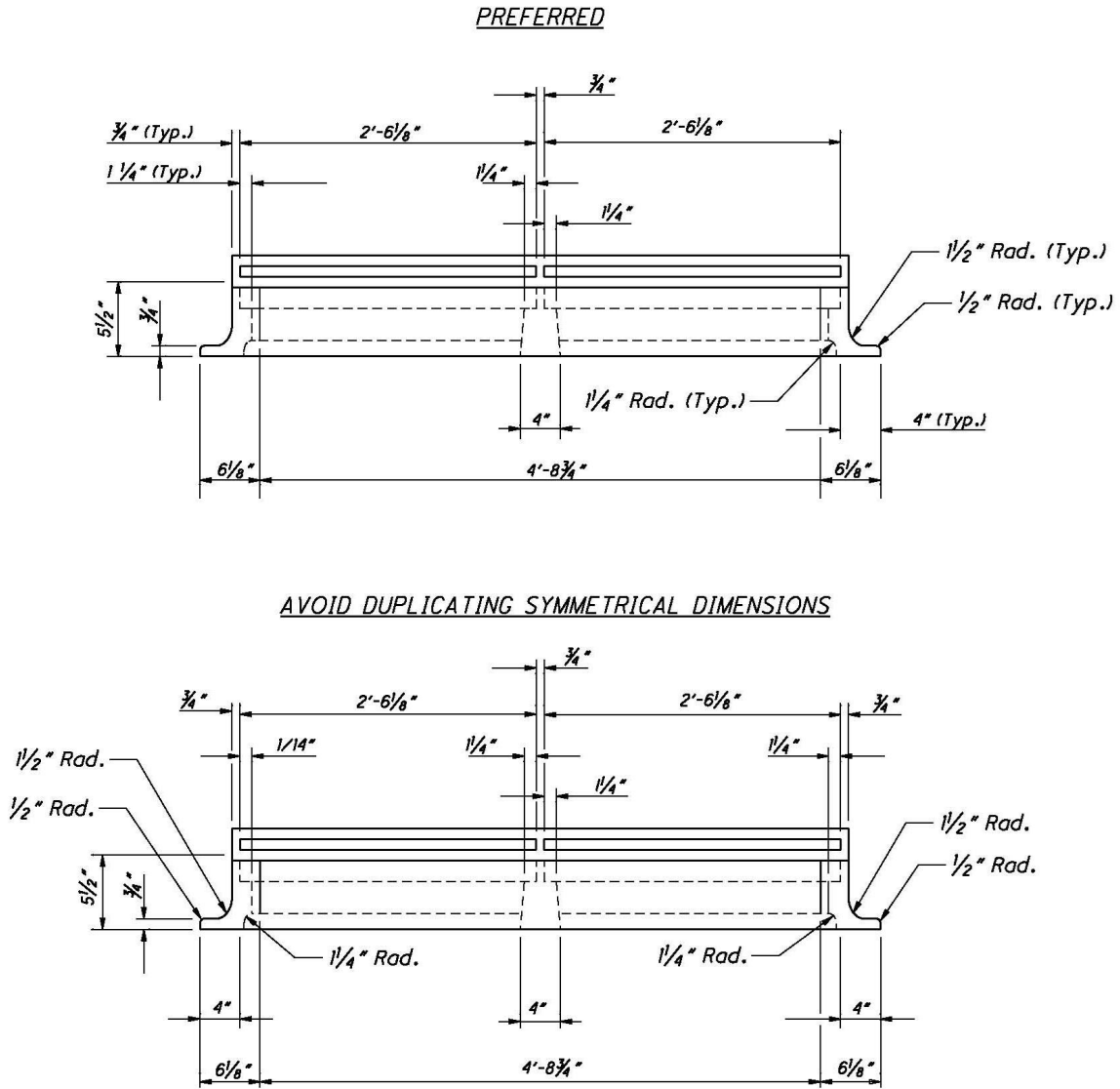

SECTION 1200 Plan Preparation

1202.5 Computer-Aided Drafting and Design (CADD)

ODOT customizations and standards for CADD software are available from the **Office of CADD and Mapping Services**, CADD Services website:

http://www.dot.state.oh.us/Divisions/Engineering/CaddMapping/CADD_Services/Pages/default.aspx

For example:

- Seed files
- Font libraries
- Cell libraries
- Standard symbology (i.e., level, weight, line style and color)
- Standard directory structure
- File naming conventions

Although ODOT accepts electronic and printed deliverables generated from Autodesk tools, at this time ODOT provides no support, standards, documentation, or guidance of any kind with respect to design and delivery using Autodesk tools.

1203 Standard Drawings

1203.1 Standard Construction Drawings

Standard Construction Drawings are an integral part of the contract plans. They are used to show repetitive details such as: manholes, curbs, guardrail, and pavement joints. When referenced in the plans, these drawings, and their associated revision dates, must be listed on the Title Sheet.

1203.2 Plan Insert Sheets

Plan Insert Sheets are similar to Standard Construction Drawings but differ in the manner in which they are included in the plans. They often cover the design of standard items that are in the development stage. Plan Insert Sheets are included with the original set of construction plans. When included in a set of construction plans, project specific information must be added to these sheets. Refer to the Design Reference Resource Center (DRRC) website (<http://www.dot.state.oh.us/drrc/Pages/default.aspx>) for the most recent version of the Plan Insert Sheets.

SECTION 1200 Plan Preparation

Figures

<u>Figure</u>	<u>Subject</u>
1201-1	Plan Sheet Dimensions
1201-2	Title Sheet Block Examples for Roadway Plans
1202-1	Acceptable Grid Systems

SECTION 1200 Plan Preparation

1201-1	Plan Sheet Dimensions
Reference Section 1201.4, 1201.5	

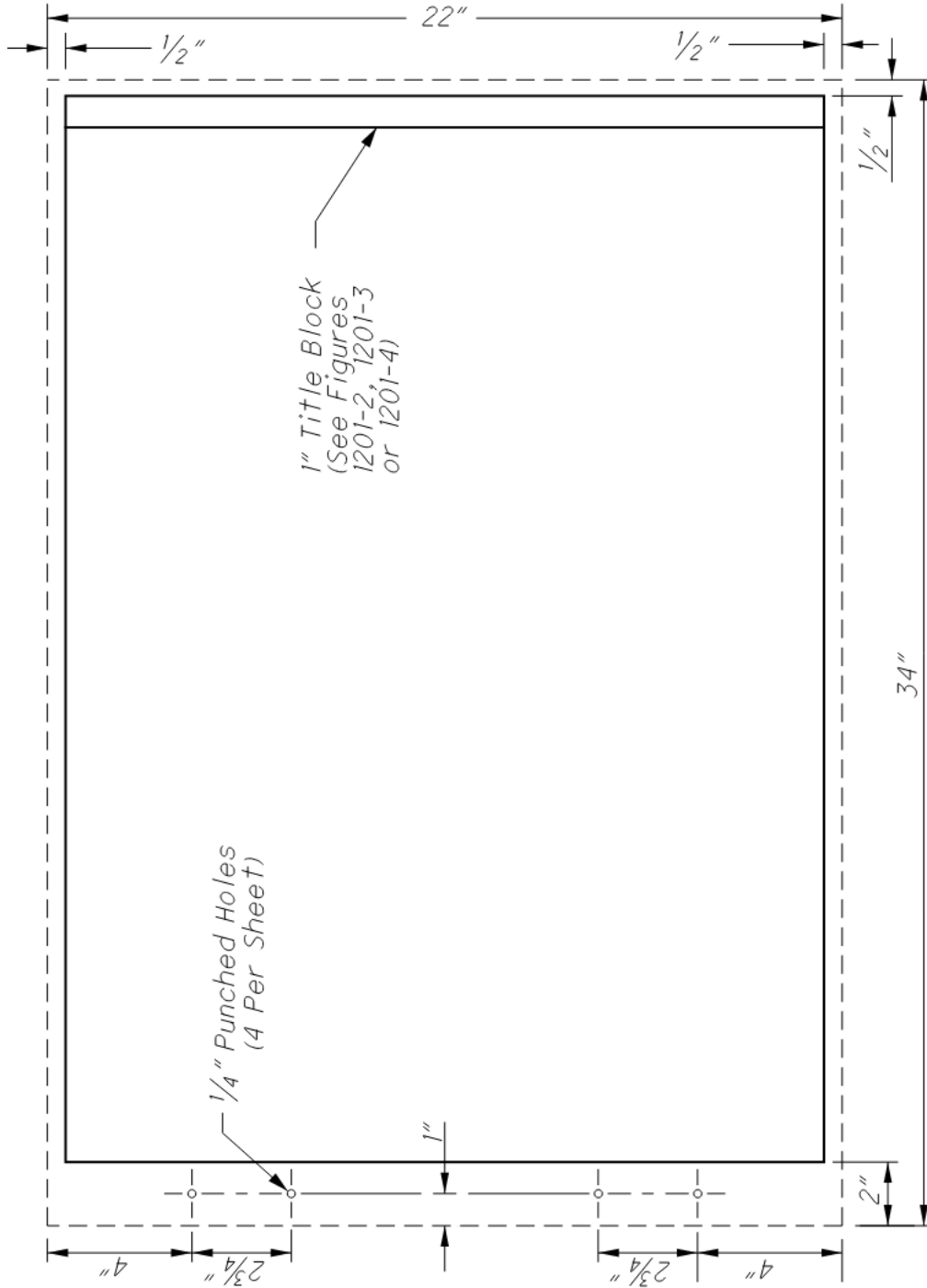

1201-2	Title Block Examples for Roadway Plans
---------------	---

SECTION 1200 Plan Preparation

Reference Section 1201.5	
-----------------------------	--

1 536	WYA - 30-2.67	RAILROAD INVOLVEMENT NONE	CONSTRUCTION PROJECT NO.	FID NO. 23436	FEDERAL PROJECT NO. E033(838)

21A 536	WYA - 30-2.67	GENERAL NOTES	CALCULATED	CHECKED

DESIGN AGENCY	
DESIGNER	
REVIEWER	
PROJECT ID 123456	
SHEET TOTAL P,0 27	

TITLE BLOCKS WITHOUT NORTH ARROW & SCALE

96DD 536	WYA - 30-2.67	PLAN AND PROFILE - U.S. 30 STA. 170+00 TO STA. 175+00	CALCULATED	CHECKED	HORIZONTAL SCALE IN FEET	

DESIGN AGENCY	
DESIGNER	
REVIEWER	
PROJECT ID 123456	
SHEET TOTAL P,0 27	

TITLE BLOCKS WITH NORTH ARROW & SCALE

Structures and Right of Way Plan Title Block information may be found in the Bridge Design Manual and the Real Estate Policies and Procedures Manual, respectively.

1202-1	Acceptable Grid Systems
--------	-------------------------

SECTION 1200 Plan Preparation

Reference Section 1202.3	
-----------------------------	--

CROSS SECTIONS

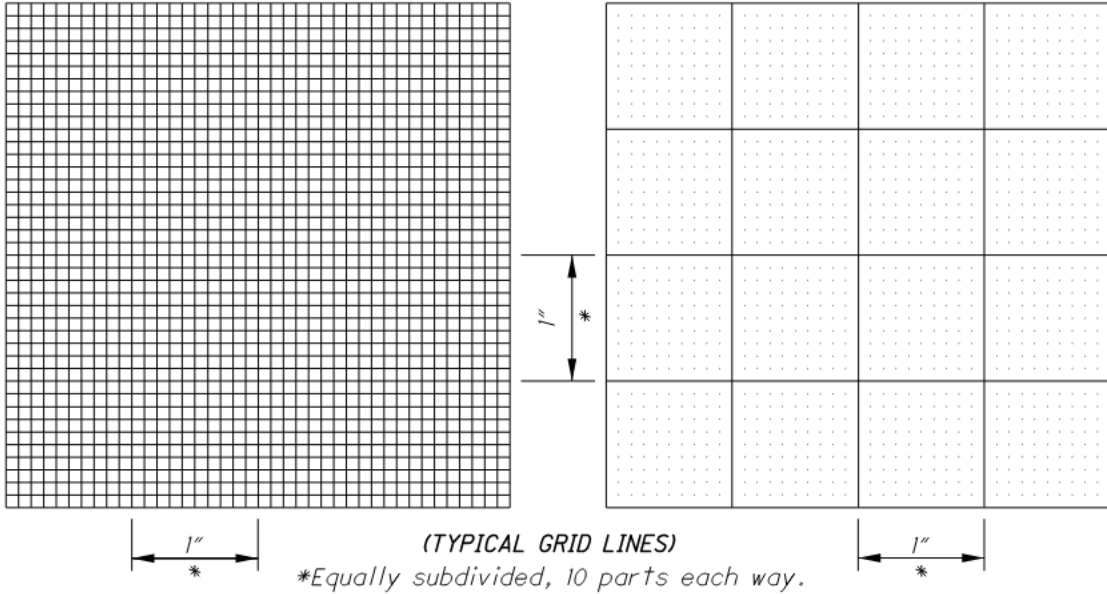

CROSS SECTIONS

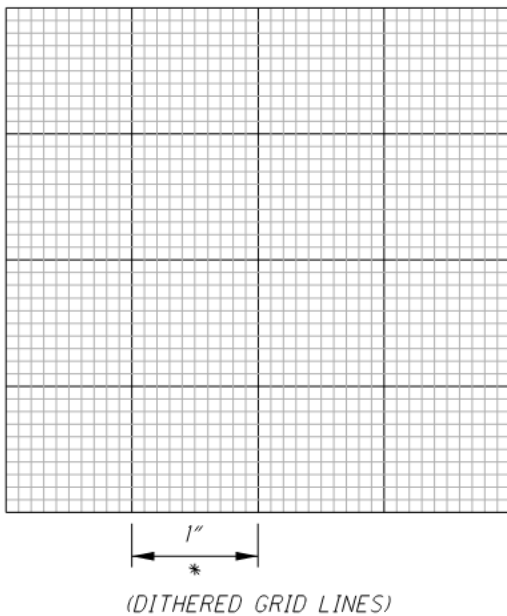

PROFILES

